

6X Series

High Power, Liquid-Cooled,
Solid State Transmitter





The 6X Series is designed to operate with most any digital or analog television standard, including ATSC, DVB-T/T2, DVB-H/SH, CMMB (STiMi), DAB, T-DMB, ISDB-T, ISDB-Tb, NTSC, PAL and more. This state-of-the-art liquid-cooled transmitter uses our frequency agile exciter and the latest LDMOS transistors for broadband operation across the entire UHF band. Axcera's liquid-cooled power amplifiers operate at the highest power density available, resulting in a very small footprint.

The completely modular design uses parallel broadband amplifiers and wide-range power supplies that can be removed and replaced while the transmitter is on the air. Since all modules are interchangeable between transmitters, regardless of channel or AC voltage and with no tuning required, multi-transmitter operators can minimize spare parts stock. This also enables simple and inexpensive channel changes.

The Axcera 6X Series liquid-cooled solid state transmitter is available in power levels up to 10kW digital in a single cabinet, with multi-cabinet configurations available up to 40kW digital. The modular construction and innovative progressive combiner design provide a clear upgrade path, allowing broadcasters to begin with a lower power transmitter and add modules in the field to achieve any power level desired.

With over 25 years of experience in the design and manufacture of solid state transmitters, Axcera continues to provide the latest technology, enabling our customers to focus on the future.

a t s c

ATSC MOBILE DTV
R E A D Y

DVB

DIGITAL READY

ISO9001:2008

6X Series Liquid-Cooled Solid State Transmitter

Universal Digital Exciter

Compliant with Worldwide Standards



This versatile exciter platform is available for most any broadcast COFDM standard, including DVB-T/T2, DVB-H/SH, CMMB (STiMi), DAB, T-DMB, ISDB-T, ISDB-Tb and more. It can also be configured to support multiple standards, allowing the user to select the desired waveform through the transmitter interface.

Axcera's Universal Digital Modulator is DSP-based and can be field upgraded with new features, and to comply with new broadcast standards as they become available. Digital precorrection compensates for both linear and non-linear distortions, and can be easily set through a very intuitive graphical user interface. A fully adaptive precorrector is also available to ensure optimal system performance over time and environmental changes with no user intervention.

For single frequency network (SFN) operation, the SFN Support option adds a MIP decoder to detect and process the SFN synchronization and compensation information. All digital settings are stored in non-volatile memory, ensuring that the system will return to normal operation following a power loss.

ATSC Exciter

100% Digital Signal Processing

For 8-VSB operation, the 6X Series uses the most advanced ATSC exciter available today. Building on the field-proven hardware platform of Axcera's digital exciter family, it offers terrestrial broadcasters the most flexible solution available. This platform supports standard ATSC (A/53) as well as ATSC Mobile DTV (A/153) and distributed transmission (A/110B) single frequency network slave modes. Because it operates using 100% digital signal processing, the exciter can evolve as broadcast requirements change, helping to protect your investment for many years to come.

Analog Exciter

Time-Proven Reliability

Axcera's industry-standard analog exciter supports worldwide analog TV standards including NTSC, PAL

and SECAM. The use of time-proven analog circuitry avoids the possibility of digital artifacts in the picture and provides extremely reliable operation with unequaled stability, performance and signal correction capability.

The exciter corrects the video input signal to ensure proper DC level, and then converts the video and audio signals to a combined, modulator RF output. Non-linear precorrection is applied to ensure excellent intermodulation performance, while linear predistortion corrects for frequency response and group delay errors, resulting in an excellent output signal.

Dual-Cast Functionality

Analog to Digital at the Touch of a Button

With Axcera's exclusive Dual-Cast option, the 6X Series is configured with both digital and analog modulators. This allows the input to be switched between analog and digital operation at the touch of a button, both locally and by remote control. As a backup transmitter, Dual-Cast allows a single 6X Series broadband transmitter to simultaneously back up both a main analog and a main digital transmitter, eliminating the need for separate analog and digital standby transmitters. Dual-Cast allows the 6X Series to "flash-cut" between analog and digital operation on demand, at the touch of a button.

Local & Remote Control & Monitoring

Extensive Diagnostics Capability

All local transmitter control and monitoring functions are available on the front panel touch screen VGA display through which the system controller provides a detailed look into the operation of the transmitter system. Parameters such as forward and reflected power, transistor currents, power supply voltages, module temperatures, event log, and much more can be viewed directly from the front of the transmitter.

For remote access, the 6X is available with Web browser and SNMP communications through an Ethernet (TCP/IP) interface. The Web browser allows real-time remote control of the transmitter system from any Internet connection and a standard PC with a Web browser, such as Microsoft® Internet Explorer. The optional SNMP client provides the ability to communicate with higher-level network management systems that support simple network management protocol (Get, Set and SNMP traps).

Power Amplifiers

Highest Power Density



Every Axcera 6X Series transmitter is comprised of highly reliable broadband amplifier modules operating in a parallel configuration. Each module uses the latest LDMOS transistors, providing very efficient and linear operation and the highest power density available today.

For convenience and ease of maintenance, each broadband hot-pluggable amplifier module operates independently, allowing easy removal and replacement while the transmitter is on the air without affecting the operation of the remaining modules. All power amplifier modules are interchangeable between positions within the transmitter and between multiple transmitters, regardless of channel. This helps to minimize spare parts stock for multiple station operators and also provides for simplified channel changes.

The combination of extensive correction capability of Axcera's digital exciters and the high linearity properties of the LDMOS devices allows all stages of the final amplifiers to operate in the very efficient class AB mode. This minimizes system power consumption while maintaining high MER and SNR performance.

Each liquid-cooled power amplifier utilizes a double-sided cooling plate design that allows it to house twice as many pallets as competing designs. This results in a very compact package, and fewer electrical and cooling connectors, thereby increasing reliability.

Power Supplies

Power Sharing for High Availability



The 6X is powered by parallel, hot-pluggable power supplies. Each supply is fully regulated with a wide input range, eliminating the need for an external automatic voltage regulator (AVR) in most installations.

Each very efficient power supply includes power factor correction, minimizing current requirements on incoming AC power service.

The power supplies operate independently of the amplifiers and are easily accessed from the front of the transmitter. As a result, replacement is simple and can be completed without removing any amplifier module and requires no special tools or training. The ratio of power supply modules to power amplifiers for standard configurations can range from 3:1 to 16:1, depending on the transmitter model, modulation and optional level of redundancy.

Since the supplies are configured in parallel with power sharing, a typical system with no redundancy will remain on the air at a reduced output power in the event a power supply module were to fail. With power sharing no single power supply module is dedicated to a specific power amplifier, providing operators the opportunity for multiple levels of power supply module redundancy. The level of power supply module redundancy available varies with the transmitter model and modulation employed. Power supply module redundancy can be configured to allow multiple power supply failures with no reduction of RF output power.

Combiners

Advanced, Modular Design



Each Axcera 6X transmitter is equipped with an advanced low-loss “progressive” type combiner. The flexible design allows sections to be added or removed, facilitating field modification to higher or lower power levels.

Because it is very compact, the combiner fits easily into the rear of the transmitter cabinet. Overall system efficiency is enhanced thanks to the very low combining loss. Additionally, cabling is eliminated through direct connections to the liquid-cooled reject loads and direct blind-mate connections to each power amplifier module. This enhances reliability and further minimizes losses by reducing the number of connection points.

Cooling System

Flexible Configurations

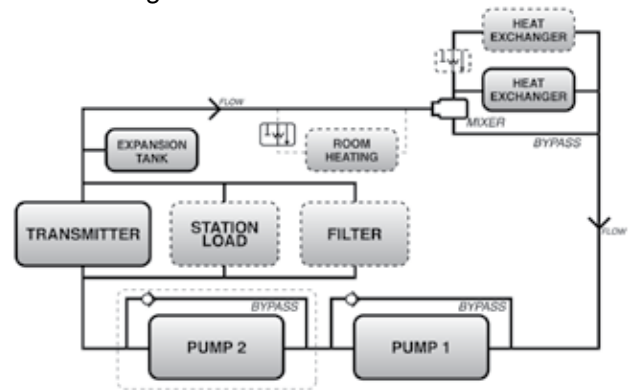

6X Series Cooling System Block Diagram

The cooling system is designed to operate with either water or a water-glycol mix, depending upon environmental conditions and user preferences. A closed cooling system design is used to minimize the amount of cooling fluid required and eliminate the need for a sump tank, again ensuring a small footprint.

Cooling fluid is directed to each power amplifier and power supply module through distribution manifolds mounted in the rear of the cabinet. This ensures that the cooling fluid flows through only one system component per cycle before returning to the heat exchanger. The system also automatically monitors and maintains the cooling fluid temperature at a constant level, helping to maximize the life of the transmitter components.



The compact heat exchanger and pump package is designed for high reliability and simple installation. For ease of maintenance and to ensure long-term support, the open-rack design uses off-the-shelf components and allows for easy access to all pumps, valves, sensors and plumbing. Configurations are available for both indoor and outdoor installation, and an N+1 cooling pump option is also available for the highest availability requirements.

Protection

High Reliability

To ensure that the 6X Series transmitter will provide reliable service in challenging environments, a high degree of protection is included. Overdrive, reflected/VSWR and over-temperature protection are all included within each power amplifier module, and RF shielded circuit enclosures help our products to operate free of interference even in high RF environments.

Reflected power is also handled at the system level with Xcera's Intelligent VSWR Protection™ (IVP). IVP actually recognizes the cause of VSWR and reacts appropriately in order to protect the entire transmission system while ensuring minimal loss of signal coverage. This unique feature determines whether the high VSWR is caused by a catastrophic problem like a transmission line arc, or if it is the result of a temporary problem such as antenna icing.

In the catastrophic case, a typical transmitter may continue to produce power, resulting in expensive antenna, transmission line or RF system repairs. But with Xcera's IVP, the system will quickly remove drive to the final amplifiers, avoiding further damage to the system components. For a temporary VSWR condition like antenna icing, the system will remain on the air at

a reduced power level, ensuring minimal coverage loss during the VSWR condition.

Lightning protection is provided through metal oxide varistors (MOVs) on the power supply inputs, and through the DC short circuit of the band pass filter (optional on some models) on the system output. High-level grounding also adds an extra measure of protection by directing lightning energy around the PA cabinet rather than through it.

Features & Benefits

Small Footprint

The 6X Series transmitter uses the latest LDMOS transistors for the highest power density available, minimizing floor space requirements.

Agile Exciter & Broadband Amplifier Modules

The frequency agile exciter and broadband solid state amplifier modules cover the entire UHF band, reducing spare parts stock and simplifying channel changes.

Parallel Amplifiers & Power Supplies

Parallel amplifier modules and power supplies provide excellent reliability and are perfect for unattended operation. N+1 power supplies ensure that the transmitter will remain at full power even if a power supply is removed from the system.

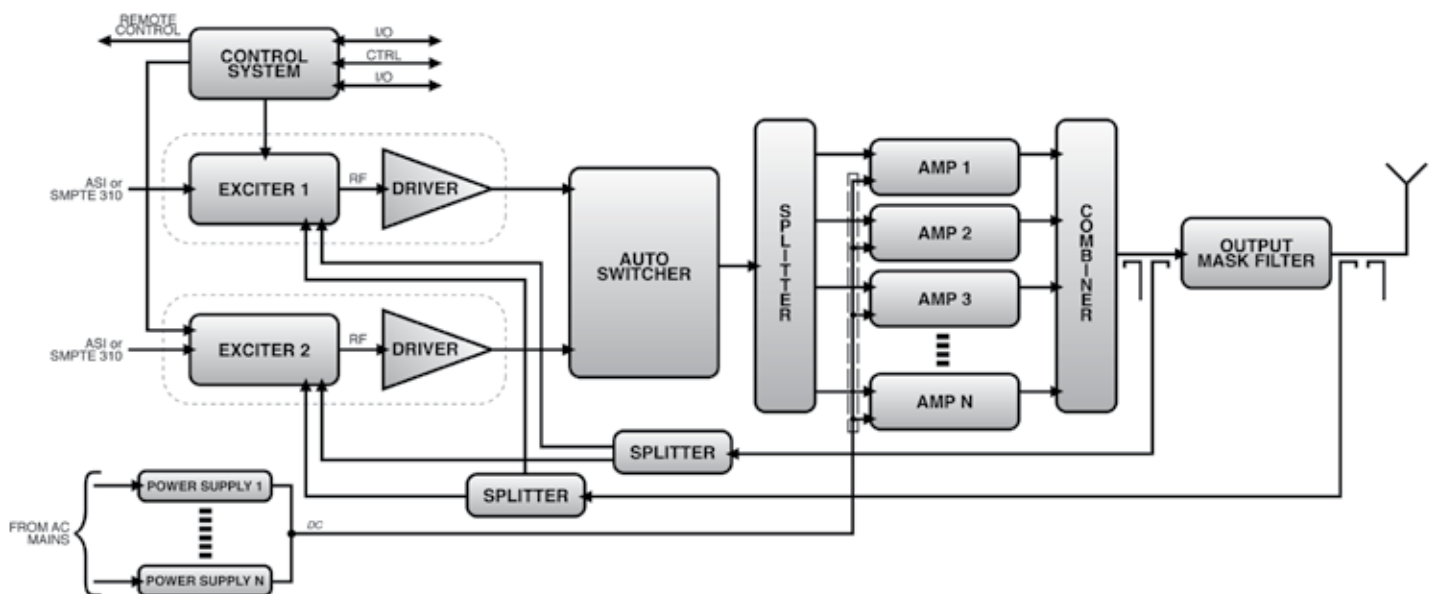

6X Series Transmitter System Block Diagram

Protection Circuitry

We have built a high degree of protection into all of our transmitters and exciter systems. Features such as IVP™ intelligent VSWR protection, over-temperature and overdrive circuits, and high-level grounding protect the system from undesirable conditions. Additionally, RF shielded circuit enclosures help our products to operate free of interference even in high RF environments.

Progressive Combiner Technology

Direct connections eliminate cabling, enhancing reliability and efficiency, and sections can be added or removed for field modification to higher or lower power levels.

Remote Control Capability

Axcera's 6X Series transmitters are available with an easily accessible interface designed to work through a Web browser or SNMP client.

World Class Product Support

All Axcera products are build under strict ISO 9001:2008 control and, with over 25 years in the industry, Axcera has never discontinued support of any of its products. That's a record that you can depend on!

International Standards Compliance

The 6X Series is in full compliance with applicable ETSI, CE, RoHS, FCC, ATSC, IEC, Industry Canada, CSA and other international standards and recommendations.



Manufacturing & Support

The 6X Series transmitter is completely designed, built and factory tested by Axcera under strict ISO 9001:2008 control. This ensures the highest quality manufacturing practices and provides parts and service availability in a very timely fashion, keeping you on the air.

Axcera is serious about our commitment to "Total Customer Happiness." When you choose our products and systems, you will also receive our relentless commitment to your overall satisfaction. Our extensive RF capabilities and experience enable us to provide design and integration services and ongoing customer service and support that are unparalleled in the broadcast industry.

Axcera offers complete RF coverage analysis, system design and integration, installation, project management and support services directly and through our global network of integration and support partners. Our knowledgeable account managers and systems engineers will work with you to ensure that you are provided with a solution that is optimal for your needs. Our world class integration, installation and support team is well recognized in the industry for its exceptional customization capabilities and installation craftsmanship.

Our industry-leading Customer Support Group is a team of experienced field service technicians available 24/7. Our team is also available to travel to your site to quickly resolve any service issues. They are also available for routine maintenance, equipment installation, proof of performance testing and product training.

**Our professional support is available by phone 1-800-215-2614 (North America only)
or +1 724-873-8100 or email: service@axcera.com.**

At Axcera, we look forward to the opportunity to demonstrate our commitment to your total happiness with our products and services.



Axcera, LLC
103 Freedom Drive
Lawrence, Pennsylvania 15055, USA

1-800-215-2614 (North America)
+1 724-873-8100 (International)
+1 724-873-8105 (Fax)

info@axcera.com
www.axcera.com

Specifications published here are current as of the date of publication of this document. Because we are continuously improving our products, Axcera reserves the right to change specifications without prior notice. At any time, you may verify product specifications by contacting our headquarters. Axcera views its patent portfolio as an important corporate asset and vigorously enforces its patents. Products or features contained herein may be covered by one or more U.S. or foreign patents.